

Logic-Circuit Connection Diagrams

A connection diagram shows all electrical connections, pin numbers, IC numbers, component values, signal names, and power supply voltages. Figure 1. Shows a typical connection diagram for a simple logic circuit.

Before looking at the circuit let us first study about what is power, ground and voltage ranges.

Power and Ground:

To use digital ICs, it is necessary to make the proper connections to the IC pins. The most important connections are *dc power* and *ground*.

The power supply pin is labeled V_{cc} for TTL circuit and V_{DD} for CMOS circuit.

Logic-level Voltage Range:

For TTL devices, V_{cc} is normally +5v. for CMOS integrated circuits, V_{DD} can range from +3 to +18 V.

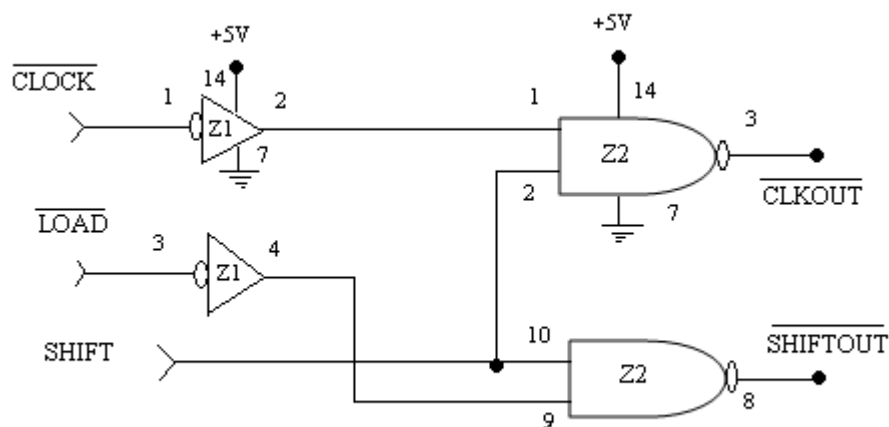

FIGURE 1

Examine the circuit carefully and note the following important points:

1. The circuit uses logic gates from two different ICs. The two INVERTERS are part of a 74HC04 chip that has been given the designation Z1. The 74HC04 chip contains 2 INVERTERS in this circuit, and each is labeled as being part of chip Z1. Similarly two NAND gates are part of a 74HC00 chip that contains four NAND gates. All of the gates in this chip are designated with the label Z2.
2. Each gate input and output pin number is indicated on the diagram. These pin numbers and IC labels are used to reference easily any point in the circuit.
3. The power and ground connections to each IC are shown on the diagram. For example Z1 pin 14 is connected to +5v, and Z1 pin 7 is connected to ground.
4. For circuit in figure 1, the signals that are inputs are on left side and the signals that are outputs are on the right.

TROUBLESHOOTING DIGITAL SYSTEMS:

There are three basic steps in fixing a digital circuit or system that has a fault:

1. **Fault detection:** Observe the circuit operation and compare it with the expected correct operation.
2. **Fault isolation:** Perform test and make measurements to isolate the fault.
3. **Fault correction:** Replace the faulty component, repair the faulty connection, remove the short and so on.

Good troubleshooting techniques can be learned only in laboratory environment through experimentation and actual troubleshooting of faulty circuits and systems. Troubleshooting technicians has the basic troubleshooting tool available : logic probe, oscilloscope, logic pulser.

The logic probe has a pointed metal tip that is touched to the specific point you want to test.

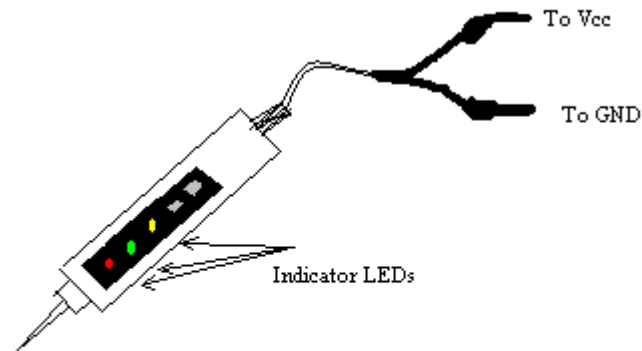

Logic Probe